

Considering the effects of UPS operation with leading power factor loads

Over the past five years, a new generation of data processing and communications equipment has become prevalent in modern data centers and network operations centers. These newer products provide beneficial increases in processing power and higher-density form factors, resulting in reduced operating costs, conservation of valuable facility space and enhanced capabilities for the enterprise. However, as performance and processing densities increase, so does the critical need to improve the “site friendliness” of the ubiquitous AC-to-DC power supplies that are utilized in today’s blade servers and communications gear. Specifically, it is beneficial to implement power factor correction (PFC) and reduced total harmonic distortion (THD) within these power supplies, which results in a total data center load that greatly reduces disturbances to a building’s electrical system, particularly when compared with data processing systems from a decade ago. At the same time, these new processors contribute toward a green data center by preserving floor space and requiring less power.

How have computer power supply designs changed?

In order to provide the benefits described above, computer power supply designs have changed significantly in recent years. At the same time, IEEE guidelines and IEC standards have placed limits on distortion and power factor (PF), which are dictating that most new data center products incorporate circuitry to help ensure compatibility with the electrical source that feeds them. One of the characteristics of these newer power supplies is the presentation of a leading, or capacitive, power factor to the input source (utility, UPS or generator). In the past, this practice was virtually unheard of, as almost all loads displayed a low power factor of approximately 0.6 to 0.8 and were lagging (inductive). As designers endeavor to produce near-unity power factors, many products now exhibit leading power factors in the 0.95 to 0.90 range, especially at light loads.

It is common to encounter lightly loaded power supplies in the increasingly common dual bus architecture, which employs multiple redundant power supplies for a given server or data storage device. In normal operation, these redundant supplies are often loaded well below 50%, which can result in a leading power factor being presented to the source, i.e. the UPS. Although this set of conditions has become increasingly common in new data centers, most UPS and generator manufacturers have not incorporated changes within their power protection equipment to accommodate this situation.

What are the challenges of leading PF loads?

Some UPS products have difficulty handling leading PF loads, most often as a result of a compatibility problem when the two are connected together as source and load. In some instances, the UPS design may not be robust enough for the leading PF of the active PFC circuits present in many of today’s IT devices. Other times, modern IT loads may contain leading PFs and/or active PFC controls that have a propensity toward instability when connected to a regulating source such as a UPS or generator. As a result, some UPSs must be significantly derated by as much as 30 to 40% to avoid such difficulties. Other UPSs with a more robust design are forgiving of such loads and provide stable operation. (See figure 1)

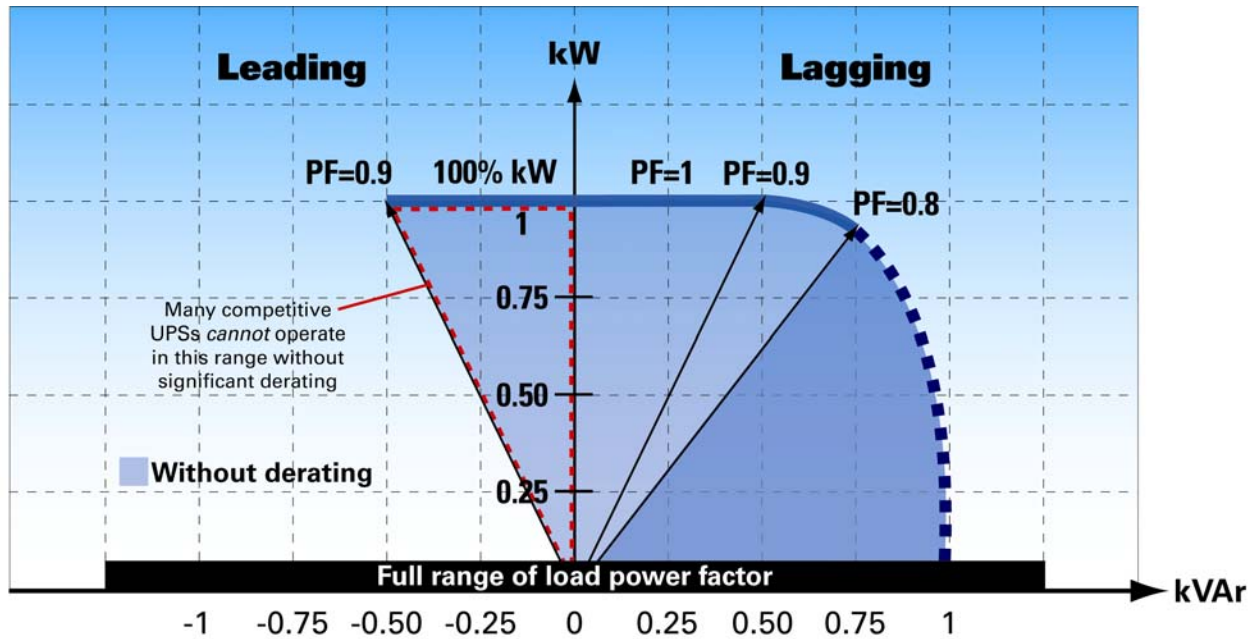

Figure 1: Full Range of Load Power Factor for Powerware® UPS

How do the output filters and control loops of a UPS relate to PF loads?

Virtually all UPSs have output filters made of inductors and capacitors. The series inductor is selected to have a low impedance while the shunt capacitor has a high impedance, in relation to the fundamental power frequency. Conversely, the inductor should have a high impedance at the inverter switching frequency to limit ripple current, while the capacitor should have a low impedance to limit output voltage ripple. The leading PF load input is connected in parallel with the output filter capacitance of the UPS. If the load has an input capacitor, it adds to the apparent net value of the UPS output filter capacitor. (see Figure 2).

A UPS has control loops that regulate its output voltage. If these loops are optimized for very fast response (under the condition of resistive or inductive loading), they may suffer instability when the output filter pole is moved significantly lower by the added load input capacitance. As a result, the output of the UPS becomes unstable when presented with a capacitive or leading PF load. A conservative UPS design with a low output impedance does not need to respond instantaneously since the output voltage deviation resulting from load changes is very small (a few percent or less). When an overly fast response time is not required, the UPS control loops can be designed to be very forgiving of the added output capacitance and continue to provide robust and stable operation, even with loads exhibiting as low as .90 leading power factor.

Control techniques in power supplies

UPSs are rated for resistive loads, with some specifically rated for lagging, leading and even nonlinear loads. Fewer models are rated for active loads with negative input impedance. The modern PFC power supplies found in most modern data center and server loads not only have a leading input PF (by virtue of the EMI capacitor) but also a negative input impedance as a result of active PFC circuitry. Often referred to as a unity input power factor supply, the name of these power supplies is misleading as it incorrectly suggests that they have a resistive load.

There are many different control techniques used in these PFC circuits that contain a wide variety of characteristics. They have all been analyzed and tested operating from a typical utility source, which has a very low source impedance (typically 3% per unit or less) and no closed loop controls, which could provoke unstable operation in the supplies with the PFC circuits. The circuits have not been analyzed or tested with all UPS output characteristics. The more the UPS mimics a typical utility source, the more likely stable operation can be expected.

There is a trend toward dual-corded server supplies – two parallel redundant supplies powered from independent sources that share the data processing load evenly. This configuration results in nominal power supply operation at less than a 50% load, which further increases the apparent leading input factor of such loads. For a typical EMI input cap of 1.0 uF per 100 watts, the input PF is .98 leading. This input EMI cap will draw five to 20 times as much current at utility frequencies as the typical output capacitance of a modern PWM based UPS. It is no surprise that this can upset the control loops of some UPS designs.

How does a large UPS support leading PF loads?

As loading on servers decreases, the leading capacitive current remains unchanged. Apparent leading PF will decrease with decreased loading. Field measurements have been reported with PFs as low as .90 leading for the aggregate and .38 leading for a single circuit or rack.

Figures 2 and 3 show V1 (a 277Vrms L-N source) with IV1 leading by 1.2 msec or 25.8 degrees which corresponds to a .90 leading PF. IR1 at 298A rms is in-phase while IC1 at 144 Arms leads by 90 degrees. R2 is used to sense current and does not impact currents more than a length of wire. It is readily seen that the large leading load capacitance, C1, is effectively in parallel with V1 – which represents the line to neutral output of the UPS (which ends in the LC low pass PWM filter). C1 effectively becomes in parallel to (and therefore added to) the existing output filter capacitor. The traces in Figure 32 below show the key circuit currents along with the UPS output voltage, V1.

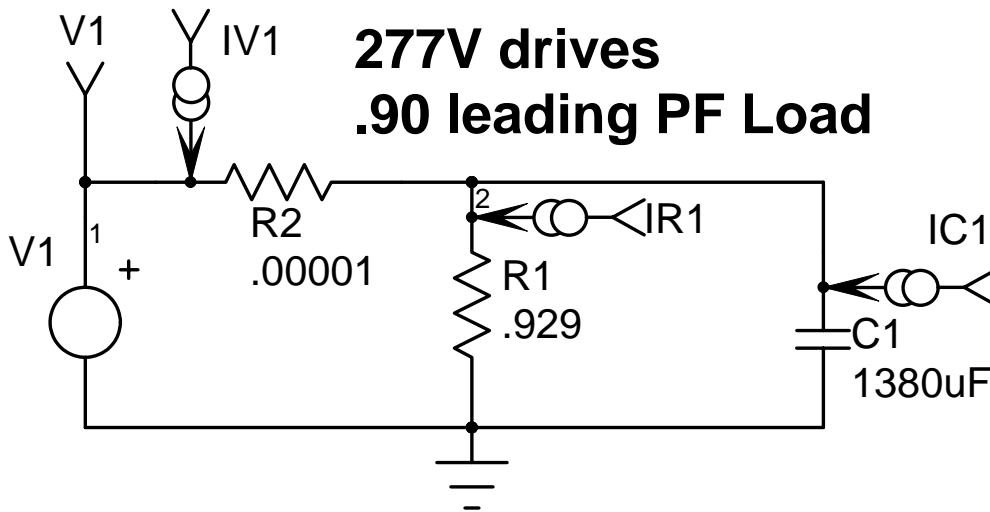

Figure 2: Equivalent Schematic of UPS with Capacitive (leading PF) load, C1

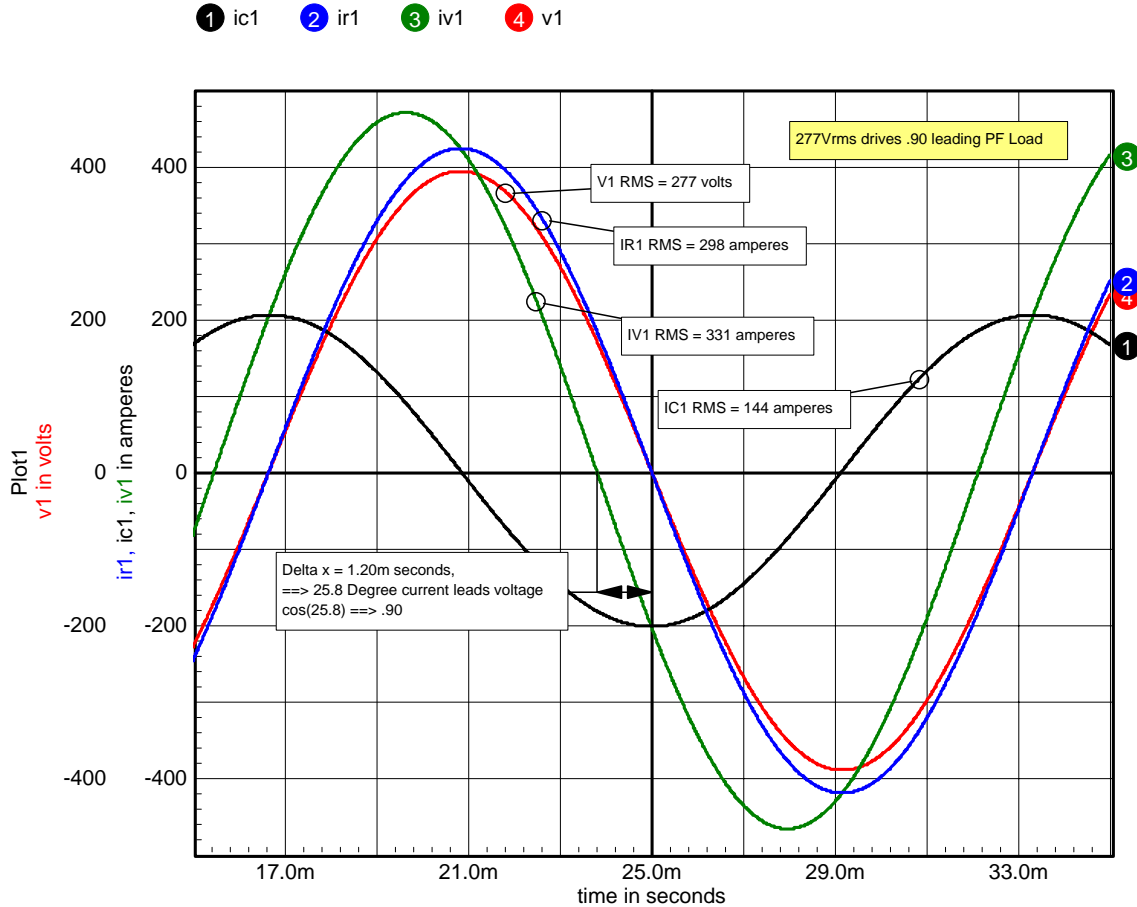

Figure 3: Waveforms resulting from analysis of schematic in Figure 2

It is important to note that it is not the absolute PF of the load that causes problems, but the leading kVAr. For example, a .90 leading load of 10 kVA (4.4 kvar leading) on a 100 kVA rated UPS may cause less difficulty than a .98 PF leading load of 90 kVA (17.9 kvar leading), since it is predominantly the amount of leading current relative to full current rating that causes the difficulties. Because of this, significant de-rating can mask the problem within the UPSs that have difficulty with leading PF. While the amount of real power loading will provide some damping and reduce the tendency toward this instability, it also depends on the particulars of the UPS control loops. Care must be taken to assure eventual loading growth will not re-expose the problem in the future. Such de-rating is often unofficial and not enforced, and there is no guarantee that future load growth will not cause the problem to resurface unexpectedly.

Pulse width modulation techniques for handling leading PF loads

The powertrain topology and control circuit design of newer UPS models can be optimized to ensure that leading loads can be supported in a stable fashion under a wide variety of operating conditions. Today's pulse width modulated (PWM) inverter systems have inherent advantages over earlier stepwave designs:

- 1) Higher switching frequency (5-20 kHz) eliminates lower order harmonics, simplifying the output filter design (no harmonic traps with their multiple resonances) and allowing smaller components to be utilized.
- 2) PWM inverters provide a lower output impedance, which ensures large phase margin, and good dynamic voltage regulation.
- 3) Digital signal processing (DSP)-based inverter voltage control is well inside output filter resonant pole, with lower gain at higher frequencies—result is more stable operation.
- 4) Controls for older stepwave designs required higher gain to offset the large inverter filter impedance for reasonable voltage regulation performance. Unfortunately, this makes the stepwave inverter more prone to instability when the load is capacitive.

Special considerations for paralleled UPS configurations

Up to this point, we have considered the causes and effects of leading PF loads and their effect on single module (non-redundant) UPS's. However, a large proportion of newer data centers utilize a parallel redundant UPS configuration consisting of up to eight identical UPS modules with their outputs tied together and in parallel electrically. If we consider the potential for unstable inverter operation spread over multiple units, which are all connected to the common critical load, the consequences are disastrous. If all of the UPS modules become unstable simultaneously, the ability to selective trip and remove failing redundant modules becomes enormously complicated, if not impossible. Selective tripping becomes even more complex and failure prone if the UPS design utilizes master/slave or primary/secondary system controls (as most competitive systems do). This scenario will very predictably result in a sudden, unexpected and poorly controlled transfer to bypass of the entire redundant UPS system. Needless to say, most large data center customers did not purchase expensive and highly redundant UPS's to have them run in bypass mode!

What are the solutions to leading PF loads?

For installations that are already showing symptoms of the problems created by leading power factor loads, there are only two feasible solutions:

- 1) Choose a UPS that is rated to handle leading power factor loads without derating. This type of UPS will have been tested to .90 or .95 PF leading.
- 2) Severe derating (up to 40%) of the UPS if it is unable to support leading loads.

Option (2) above, could result in incremental cost increases of as much as 30% over the base cost of the power protection equipment. Fortunately, there are UPS products readily available which are designed to handle these loads.

Conclusion

In this paper, we have explored the relatively new trend of leading PF loads in the data center and network center environments. The causes and symptoms of this practice were described, along with a typical example of the UPS—leading load interface, in an effort to provide an overview of this increasingly common issue and its potential repercussions for the modern data center designer and user. IT managers should consider the possible effects of leading power factor loads in the early stages of data center design as they may affect the choice of power protection systems including UPSs, power conditioners, power distribution units (PDU) and generator backup systems.

Eaton—Setting the standard for three-phase UPS power protection

For more than 40 years—from the first commercial UPS to the new, high-efficiency Powerware 9395 UPS—Powerware UPSs from Eaton have set the standard for power protection and backup, and helped Eaton earn the designation of “Power Quality Company of the Year” from Frost & Sullivan for three years in a row. To find out more, visit us on the Web at www.powerware.com or call us at 800-356-5794.